

## 8. Bearing Internal Clearance and Preload

### 8.1 Bearing internal clearance

Bearing internal clearance is the amount of internal free movement before mounting.

As shown in **Fig. 8.1**, when either the inner ring or the outer ring is fixed and the other ring is free to move, displacement can take place in either an axial or radial direction. This amount of displacement (radially or axially) is termed the internal clearance and, depending on the direction, is called the radial internal clearance or the axial internal clearance.

When the internal clearance of a bearing is measured, a slight measurement load is applied to the raceway so the internal clearance may be measured accurately. However, at this time, a slight amount of elastic deformation of the bearing occurs under the measurement load, and the clearance measurement value (measured clearance) is slightly larger than the true clearance. This difference between the true bearing clearance and the increased amount due to the elastic deformation must be compensated for. These compensation values are given in **Table 8.1**. For roller bearings the amount of elastic deformation can be ignored.

The internal clearance values for each bearing class are shown in **Tables 8.3** through **8.11**.

### 8.2 Internal clearance selection

The internal clearance of a bearing under operating conditions (effective clearance) is usually smaller than the same bearing's initial clearance before being installed and operated. This is due to several factors including bearing fit, the difference in temperature between the inner and outer rings, etc. As a bearing's operating clearance has an effect on bearing life, heat generation, vibration, noise, etc.; care must be taken in selecting the most suitable operating clearance.

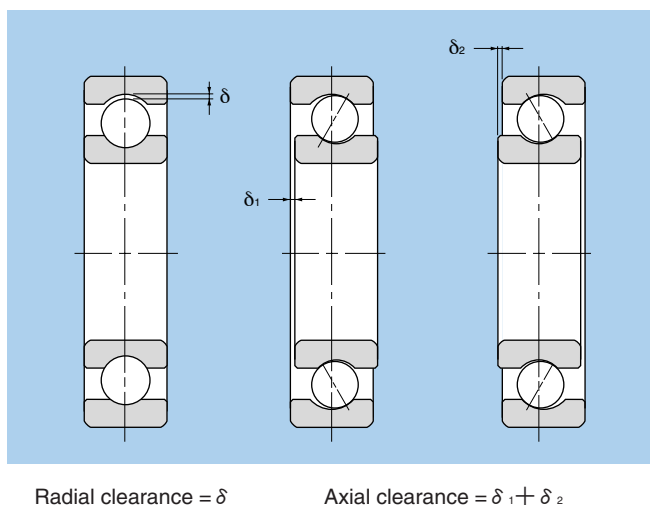

**Fig. 8.1 Internal clearance**

### 8.2.1 Criteria for selecting bearing internal clearance

A bearing's life is theoretically maximum when operating clearance is slightly negative at steady operation. In reality it is however difficult to constantly maintain this optimal condition. If the negative clearance becomes enlarged by fluctuating operating conditions, heat will be produced and life will decrease dramatically. Under ordinary circumstances you should therefore select an initial internal clearance where the operating clearance is slightly larger than zero.

For ordinary operating conditions, use fitting for ordinary loads. If rotational speed and operating temperature are ordinary, selecting normal clearance enables you to obtain the proper operating clearance. **Table 8.2** gives examples applying internal clearances other than CN (normal) clearance.

### 8.2.2 Calculation of operating clearance

Operating clearance of a bearing can be calculated from initial bearing internal clearance and decrease in internal clearance due to interference and decrease in internal clearance due to difference in temperature of the inner and outer rings.

$$\delta_{\text{eff}} = \delta_o - (\delta_f + \delta_t) \dots\dots\dots (8.1)$$

where,

$\delta_{\text{eff}}$  : Effective internal clearance, mm

$\delta_o$  : Bearing internal clearance, mm

$\delta_f$  : Reduced amount of clearance due to

**Table 8.1 Adjustment of radial internal clearance based on measured load (deep groove ball bearing)** Unit  $\mu\text{m}$

Nominal Bore Diameter $d$ mm	Measuring Load N {kgf}	Internal clearance adjustment						
		over	incl.	C2	CN	C3	C4	C5
10 ①	18	24.5	{2.5}	3~4	4	4	4	4
18	50	49	{5}	4~5	5	6	6	6
50	200	147	{15}	6~8	8	9	9	9

① This diameter is included in the group.

**Table 8.2 Examples of applications where bearing clearances other than CN (normal) clearance are used**

Operating conditions	Applications	Selected clearance
With heavy or shock load, clearance is large.	Railway vehicle axles	C3
	Vibration screens	C3, C4
With indeterminate load, both inner and outer rings are tight-fitted.	Railway vehicle traction motors	C4
	Tractors and final speed regulators	C4
Shaft or inner ring is heated.	Paper making machines and driers	C3, C4
	Rolling mill table rollers	C3
Reduction of noise and vibration when rotating.	Micromotors	C2, CM
Adjustment of clearance to minimize shaft runout.	Main spindles of lathes (Double-row cylindrical roller bearings)	C9NA, C0NA
Loose fitting for both inner and outer rings.	Compressor roll neck	C2

interference, mm

$\delta_t$  : Reduced amount of clearance due to temperature differential of inner and outer rings, mm

### (1) Reduced clearance due to interference

When bearings are installed with interference fits on shafts and in housings, the inner ring will expand and the outer ring will contract; **thus reducing the bearings' internal clearance.** The amount of expansion or contraction varies depending on the shape of the bearing, the shape of the shaft or housing, dimensions of the respective parts, and the type of materials used. The differential can range from approximately **70% to 90% of the effective interference.**

$$\delta_t = (0.70 \sim 0.90) \Delta_{def} \dots\dots\dots (8.2)$$

where,

$\delta_t$  : Reduced amount of clearance due to interference, mm

$\Delta_{def}$  : Effective interference, mm

### (2) Reduced internal clearance due to inner/outer ring temperature difference.

During operation, normally the outer ring will range from 5 to 10°C cooler than the inner ring or rotating parts. However, if the cooling effect of the housing is large, the

shaft is connected to a heat source, or a heated substance is conducted through the hollow shaft; the temperature difference between the two rings can be even greater. **The amount of internal clearance is thus further reduced by the differential expansion of the two rings.**

$$\delta_t = \alpha \cdot \Delta T \cdot D_o \dots\dots\dots (8.3)$$

where,

$\delta_t$  : Amount of reduced clearance due to heat differential, mm

$\alpha$  : Bearing material expansion coefficient  
 $12.5 \times 10^{-6}/^\circ\text{C}$

$\Delta T$  : Inner/outer ring temperature differential, °C

$D_o$  : Outer ring raceway diameter, mm

Outer ring raceway diameter,  $D_o$ , values can be approximated by using formula (8.4) or (8.5).

For ball bearings and spherical roller bearings,

$$D_o = 0.20 (d + 4.0D) \dots\dots\dots (8.4)$$

For roller bearings (except Spherical roller bearing),

$$D_o = 0.25 (d + 3.0D) \dots\dots\dots (8.5)$$

where,

$d$  : Bearing bore diameter, mm

$D$  : Bearing outside diameter, mm

**Table 8.3 Radial internal clearance of deep groove ball bearings**

Unit  $\mu\text{m}$

Nominal bore diameter $d$ mm		C2		CN		C3		C4		C5	
over	incl.	min	max	min	max	min	max	min	max	min	max
—	2.5	0	6	4	11	10	20	—	—	—	—
2.5	6	0	7	2	13	8	23	—	—	—	—
6	10	0	7	2	13	8	23	14	29	20	37
10	18	0	9	3	18	11	25	18	33	25	45
18	24	0	10	5	20	13	28	20	36	28	48
24	30	1	11	5	20	13	28	23	41	30	53
30	40	1	11	6	20	15	33	28	46	40	64
40	50	1	11	6	23	18	36	30	51	45	73
50	65	1	15	8	28	23	43	38	61	55	90
65	80	1	15	10	30	25	51	46	71	65	105
80	100	1	18	12	36	30	58	53	84	75	120
100	120	2	20	15	41	36	66	61	97	90	140
120	140	2	23	18	48	41	81	71	114	105	160
140	160	2	23	18	53	46	91	81	130	120	180
160	180	2	25	20	61	53	102	91	147	135	200
180	200	2	30	25	71	63	117	107	163	150	230
200	225	2	35	25	85	75	140	125	195	175	265
225	250	2	40	30	95	85	160	145	225	205	300
250	280	2	45	35	105	90	170	155	245	225	340
280	315	2	55	40	115	100	190	175	270	245	370
315	355	3	60	45	125	110	210	195	300	275	410
355	400	3	70	55	145	130	240	225	340	315	460
400	450	3	80	60	170	150	270	250	380	350	510
450	500	3	90	70	190	170	300	280	420	390	570
500	560	10	100	80	210	190	330	310	470	440	630
560	630	10	110	90	230	210	360	340	520	490	690

**Table 8.4 Radial internal clearance of self-aligning ball bearings**

Nominal bore diameter <i>d</i> mm		Bearing with cylindrical bore									
		C2		CN		C3		C4		C5	
over	incl.	min	max	min	max	min	max	min	max	min	max
2.5	6	1	8	5	15	10	20	15	25	21	33
6	10	2	9	6	17	12	25	19	33	27	42
10	14	2	10	6	19	13	26	21	35	30	48
14	18	3	12	8	21	15	28	23	37	32	50
18	24	4	14	10	23	17	30	25	39	34	52
24	30	5	16	11	24	19	35	29	46	40	58
30	40	6	18	13	29	23	40	34	53	46	66
40	50	6	19	14	31	25	44	37	57	50	71
50	65	7	21	16	36	30	50	45	69	62	88
65	80	8	24	18	40	35	60	54	83	76	108
80	100	9	27	22	48	42	70	64	96	89	124
100	120	10	31	25	56	50	83	75	114	105	145
120	140	10	38	30	68	60	100	90	135	125	175
140	160	15	44	35	80	70	120	110	161	150	210

**Table 8.5 (1) Radial internal clearance for duplex angular contact ball bearings**

Unit  $\mu\text{m}$

Nominal bore diameter <i>d</i> mm	C1		C2		CN		C3		C4		
	over	incl.	min	max	min	max	min	max	min	max	
—	10	3	8	6	12	8	15	15	22	22	30
10	18	3	8	6	12	8	15	15	24	30	40
18	30	3	10	6	12	10	20	20	32	40	55
30	50	3	10	8	14	14	25	25	40	55	75
50	80	3	11	11	17	17	32	32	50	75	95
80	100	3	13	13	22	22	40	40	60	95	120
100	120	3	15	15	30	30	50	50	75	110	140
120	150	3	16	16	33	35	55	55	80	130	170
150	180	3	18	18	35	35	60	60	90	150	200
180	200	3	20	20	40	40	65	65	100	180	240

Note: The clearance group in the table is applied only to contact angles in the table below.

Contact angle symbol	Nominal contact angle	Applicable clearance group <sup>②</sup>
C	15°	C1, C2
A <sup>①</sup>	30°	C2, CN, C3
B	40°	CN, C3, C4

① Not indicated for bearing number.

② For information concerning clearance other than applicable clearance, please contact NTN Engineering.

**Table 8.5 (2) Radial internal clearance of double row angular contact ball bearings**

Unit  $\mu\text{m}$

Nominal bore diameter <i>d</i> mm	C2		CN		C3		C4		C5		
	over	incl.	min	max	min	max	min	max	min	max	
10 only	0	10	5	15	10	21	16	28	24	36	
10	18	1	11	6	16	12	23	19	31	28	40
18	24	1	11	6	16	13	24	21	33	31	43
24	30	1	13	6	19	13	26	21	35	31	45
30	40	2	15	7	22	15	30	24	39	35	50
40	50	2	15	9	24	17	32	28	45	40	57
50	65	0	15	7	24	16	33	28	48	41	61
65	80	1	17	11	31	21	42	34	56	50	74
80	100	3	20	13	36	25	49	40	65	58	67

**Table 8.6 Radial internal clearance of bearings for electric motor**

Unit  $\mu\text{m}$

Nominal bore diameter <i>d</i> mm		Radial internal clearance CM			
		Deep groove ball bearings		Cylindrical roller bearings	
over	incl.	min	max	min	max
10 (incl.)	18	4	11	—	—
18	24	5	12	—	—
24	30	5	12	15	30
30	40	9	17	15	30
40	50	9	17	20	35
50	65	12	22	25	40
65	80	12	22	30	45
80	100	18	30	35	55
100	120	18	30	35	60
120	140	24	38	40	65
140	160	24	38	50	80
160	180	—	—	60	90
180	200	—	—	65	100

Note 1: Suffix CM is added to bearing numbers.

Example: 6205ZZCM

2: Clearance not interchangeable for cylindrical roller bearings.

Unit  $\mu\text{m}$ 

Bearing with tapered bore										Nominal bore diameter	
C2		CN		C3		C4		C5		$d$ mm	
min	max	min	max	min	max	min	max	min	max	over	incl.
—	—	—	—	—	—	—	—	—	—	2.5	6
—	—	—	—	—	—	—	—	—	—	6	10
—	—	—	—	—	—	—	—	—	—	10	14
—	—	—	—	—	—	—	—	—	—	14	18
7	17	13	26	20	33	28	42	37	55	18	24
9	20	15	28	23	39	33	50	44	62	24	30
12	24	19	35	29	46	40	59	52	72	30	40
14	27	22	39	33	52	45	65	58	79	40	50
18	32	27	47	41	61	56	80	73	99	50	65
23	39	35	57	50	75	69	98	91	123	65	80
29	47	42	68	62	90	84	116	109	144	80	100
35	56	50	81	75	108	100	139	130	170	100	120
40	68	60	98	90	130	120	165	155	205	120	140
45	74	65	110	100	150	140	191	180	240	140	160

**Table 8.7 Interchangeable radial internal clearance for cylindrical roller bearing (cylindrical bore)**

 Unit  $\mu\text{m}$ 

Nominal bore diameter $d$ mm		C2		CN		C3		C4		C5	
over	incl.	min	max	min	max	min	max	min	max	min	max
—	10	0	25	20	45	35	60	50	75	—	—
10	24	0	25	20	45	35	60	50	75	65	90
24	30	0	25	20	45	35	60	50	75	70	95
30	40	5	30	25	50	45	70	60	85	80	105
40	50	5	35	30	60	50	80	70	100	95	125
50	65	10	40	40	70	60	90	80	110	110	140
65	80	10	45	40	75	65	100	90	125	130	165
80	100	15	50	50	85	75	110	105	140	155	190
100	120	15	55	50	90	85	125	125	165	180	220
120	140	15	60	60	105	100	145	145	190	200	245
140	160	20	70	70	120	115	165	165	215	225	275
160	180	25	75	75	125	120	170	170	220	250	300
180	200	35	90	90	145	140	195	195	250	275	330
200	225	45	105	105	165	160	220	220	280	305	365
225	250	45	110	110	175	170	235	235	300	330	395
250	280	55	125	125	195	190	260	260	330	370	440
280	315	55	130	130	205	200	275	275	350	410	485
315	355	65	145	145	225	225	305	305	385	455	535
355	400	100	190	190	280	280	370	370	460	510	600
400	450	110	210	210	310	310	410	410	510	565	665
450	500	110	220	220	330	330	440	440	550	625	735

**Table 8.8 Non-interchangeable radial internal clearance for cylindrical roller bearing**

Nominal bore diameter <i>d</i> mm		Bearing with cylindrical bore											
		C1NA		C2NA		NA <sup>●</sup>		C3NA		C4NA		C5NA	
over	incl.	min	max	min	max	min	max	min	max	min	max	min	max
—	10	5	10	10	20	20	30	35	45	45	55	—	—
10	18	5	10	10	20	20	30	35	45	45	55	65	75
18	24	5	10	10	20	20	30	35	45	45	55	65	75
24	30	5	10	10	25	25	35	40	50	50	60	70	80
30	40	5	12	12	25	25	40	45	55	55	70	80	95
40	50	5	15	15	30	30	45	50	65	65	80	95	110
50	65	5	15	15	35	35	50	55	75	75	90	110	130
65	80	10	20	20	40	40	60	70	90	90	110	130	150
80	100	10	25	25	45	45	70	80	105	105	125	155	180
100	120	10	25	25	50	50	80	95	120	120	145	180	205
120	140	15	30	30	60	60	90	105	135	135	160	200	230
140	160	15	35	35	65	65	100	115	150	150	180	225	260
160	180	15	35	35	75	75	110	125	165	165	200	250	285
180	200	20	40	40	80	80	120	140	180	180	220	275	315
200	225	20	45	45	90	90	135	155	200	200	240	305	350
225	250	25	50	50	100	100	150	170	215	215	265	330	380
250	280	25	55	55	110	110	165	185	240	240	295	370	420
280	315	30	60	60	120	120	180	205	265	265	325	410	470
315	355	30	65	65	135	135	200	225	295	295	360	455	520
355	400	35	75	75	150	150	225	255	330	330	405	510	585
400	450	45	85	85	170	170	255	285	370	370	455	565	650
450	500	50	95	95	190	190	285	315	410	410	505	625	720

● For bearings with normal clearance, only NA is added to bearing numbers. Ex. NU310NA

**Table 8.9 Axial internal clearance for double row and duplex tapered roller bearings (metric series)**

Nominal bore diameter <i>d</i> mm		Contact angle $\alpha \leq 27^\circ$ ( $e \leq 0.76$ )							
		C2		CN		C3		C4	
over	incl.	min	max	min	max	min	max	min	max
18	24	25	75	75	125	125	170	170	220
24	30	25	75	75	125	145	195	195	245
30	40	25	95	95	165	165	235	210	280
40	50	20	85	85	150	175	240	240	305
50	65	20	85	110	175	195	260	280	350
65	80	20	110	130	220	240	325	325	410
80	100	45	150	150	260	280	390	390	500
100	120	45	175	175	305	350	480	455	585
120	140	45	175	175	305	390	520	500	630
140	160	60	200	200	340	400	540	520	660
160	180	80	220	240	380	440	580	600	740
180	200	100	260	260	420	500	660	660	820
200	225	120	300	300	480	560	740	720	900
225	250	160	360	360	560	620	820	820	1,020
250	280	180	400	400	620	700	920	920	1,140
280	315	200	440	440	680	780	1,020	1,020	1,260
315	355	220	480	500	760	860	1,120	1,120	1,380
355	400	260	560	560	860	980	1,280	1,280	1,580
400	500	300	600	620	920	1,100	1,400	1,440	1,740

Note1: This table applies to bearings contained in the catalog. For information concerning other bearings or bearings using US customary unit, please contact NTN Engineering.

2: The correlation of axial internal clearance ( $\Delta_a$ ) and radial internal clearance ( $\Delta_r$ ) is expressed as  $\Delta_r = 0.667 \cdot e \cdot \Delta_a$ .

*e*: Constant (see dimensions table)

3: Bearing series 329X, 330, 322C and 323Cdo not apply to the table.

Unit  $\mu\text{m}$ 

Bearing with tapered bore												Nominal bore diameter	
C9NA <sup>②</sup>		C0NA <sup>②</sup>		C1NA		C2NA		NA <sup>①</sup>		C3NA		<i>d</i> mm	
min	max	min	max	min	max	min	max	min	max	min	max	over	incl.
5	5	7	17	10	20	20	30	35	45	45	55	—	10
5	10	7	17	10	20	20	30	35	45	45	55	10	18
5	10	7	17	10	20	20	30	35	45	45	55	18	24
5	10	10	20	10	25	25	35	40	50	50	60	24	30
5	12	10	20	12	25	25	40	45	55	55	70	30	40
5	15	10	20	15	30	30	45	50	65	65	80	40	50
5	15	10	20	15	35	35	50	55	75	75	90	50	65
10	20	15	30	20	40	40	60	70	90	90	110	65	80
10	25	20	35	25	45	45	70	80	105	105	125	80	100
10	25	20	35	25	50	50	80	95	120	120	145	100	120
15	30	25	40	30	60	60	90	105	135	135	160	120	140
15	35	30	45	35	65	65	100	115	150	150	180	140	160
15	35	30	45	35	75	75	110	125	165	165	200	160	180
20	40	30	50	40	80	80	120	140	180	180	220	180	200
20	45	35	55	45	90	90	135	155	200	200	240	200	225
25	50	40	65	50	100	100	150	170	215	215	265	225	250
25	55	40	65	55	110	110	165	185	240	240	295	250	280
30	60	45	75	60	120	120	180	205	265	265	325	280	315
30	65	45	75	65	135	135	200	225	295	295	360	315	355
35	75	50	90	75	150	150	225	255	330	330	405	355	400
45	85	60	100	85	170	170	255	285	370	370	455	400	450
50	95	70	115	95	190	190	285	315	410	410	505	450	500

② C9NA, C0NA and C1NA are applied only to precision bearings of Class 5 and higher.

 Unit  $\mu\text{m}$ 

Contact angle $\alpha > 27^\circ$ ( $e > 0.76$ )								Nominal bore diameter	
C2		CN		C3		C4		<i>d</i> mm	
min	max	min	max	min	max	min	max	over	incl.
10	30	30	50	50	70	70	90	18	24
10	30	30	50	60	80	80	100	24	30
10	40	40	70	70	100	90	120	30	40
10	40	40	70	80	110	110	140	40	50
10	40	50	80	90	120	130	160	50	65
10	50	60	100	110	150	150	190	65	80
20	70	70	120	130	180	180	230	80	100
20	70	70	120	150	200	210	260	100	120
20	70	70	120	160	210	210	260	120	140
30	100	100	160	180	240	240	300	140	160
—	—	—	—	—	—	—	—	160	180
—	—	—	—	—	—	—	—	180	200
—	—	—	—	—	—	—	—	200	225
—	—	—	—	—	—	—	—	225	250
—	—	—	—	—	—	—	—	250	280
—	—	—	—	—	—	—	—	280	315
—	—	—	—	—	—	—	—	315	355
—	—	—	—	—	—	—	—	355	400
—	—	—	—	—	—	—	—	400	500

**Table 8.10 Radial internal clearance of spherical roller bearings**

Nominal bore diameter <i>d</i> mm		Bearing with cylindrical bore									
		C2		CN		C3		C4		C5	
over	incl.	min	max	min	max	min	max	min	max	min	max
14	18	10	20	20	35	35	45	45	60	60	75
18	24	10	20	20	35	35	45	45	60	60	75
24	30	15	25	25	40	40	55	55	75	75	95
30	40	15	30	30	45	45	60	60	80	80	100
40	50	20	35	35	55	55	75	75	100	100	125
50	65	20	40	40	65	65	90	90	120	120	150
65	80	30	50	50	80	80	110	110	145	145	180
80	100	35	60	60	100	100	135	135	180	180	225
100	120	40	75	75	120	120	160	160	210	210	260
120	140	50	95	95	145	145	190	190	240	240	300
140	160	60	110	110	170	170	220	220	280	280	350
160	180	65	120	120	180	180	240	240	310	310	390
180	200	70	130	130	200	200	260	260	340	340	430
200	225	80	140	140	220	220	290	290	380	380	470
225	250	90	150	150	240	240	320	320	420	420	520
250	280	100	170	170	260	260	350	350	460	460	570
280	315	110	190	190	280	280	370	370	500	500	630
315	355	120	200	200	310	310	410	410	550	550	690
355	400	130	220	220	340	340	450	450	600	600	750
400	450	140	240	240	370	370	500	500	660	660	820
450	500	140	260	260	410	410	550	550	720	720	900
500	560	150	280	280	440	440	600	600	780	780	1,000
560	630	170	310	310	480	480	650	650	850	850	1,100
630	710	190	350	350	530	530	700	700	920	920	1,190
710	800	210	390	390	580	580	770	770	1,010	1,010	1,300
800	900	230	430	430	650	650	860	860	1,120	1,120	1,440
900	1,000	260	480	480	710	710	930	930	1,220	1,220	1,570
1,000	1,120	290	530	530	780	780	1,020	1,020	1,330	1,330	1,720
1,120	1,250	320	580	580	860	860	1,120	1,120	1,460	1,460	1,870
1,250	1,400	350	640	640	950	950	1,240	1,240	1,620	1,620	2,080

**Table 8.11 Axial internal clearance of four points contact ball bearings**

Unit  $\mu\text{m}$

Nominal bore diameter <i>d</i> mm		C2		CN		C3		C4	
		min	max	min	max	min	max	min	max
over	incl.								
17	40	26	66	56	106	96	146	136	186
40	60	36	86	76	126	116	166	156	206
60	80	46	96	86	136	126	176	166	226
80	100	56	106	96	156	136	196	186	246
100	140	66	126	116	176	156	216	206	266
140	180	76	156	136	196	176	236	226	296
180	220	96	176	156	216	196	256	246	316

Unit  $\mu\text{m}$ 

Bearing with tapered bore										Nominal bore diameter	
C2		CN		C3		C4		C5		$d$ mm	
min	max	min	max	min	max	min	max	min	max	over	incl.
—	—	—	—	—	—	—	—	—	—	14	18
15	25	25	35	35	45	45	60	60	75	18	24
20	30	30	40	40	55	55	75	75	95	24	30
25	35	35	50	50	65	65	85	85	105	30	40
30	45	45	60	60	80	80	100	100	130	40	50
40	55	55	75	75	95	95	120	120	160	50	65
50	70	70	95	95	120	120	150	150	200	65	80
55	80	80	110	110	140	140	180	180	230	80	100
65	100	100	135	135	170	170	220	220	280	100	120
80	120	120	160	160	200	200	260	260	330	120	140
90	130	130	180	180	230	230	300	300	380	140	160
100	140	140	200	200	260	260	340	340	430	160	180
110	160	160	220	220	290	290	370	370	470	180	200
120	180	180	250	250	320	320	410	410	520	200	225
140	200	200	270	270	350	350	450	450	570	225	250
150	220	220	300	300	390	390	490	490	620	250	280
170	240	240	330	330	430	430	540	540	680	280	315
190	270	270	360	360	470	470	590	590	740	315	355
210	300	300	400	400	520	520	650	650	820	355	400
230	330	330	440	440	570	570	720	720	910	400	450
260	370	370	490	490	630	630	790	790	1,000	450	500
290	410	410	540	540	680	680	870	870	1,100	500	560
320	460	460	600	600	760	760	980	980	1,230	560	630
350	510	510	670	670	850	850	1,090	1,090	1,360	630	710
390	570	570	750	750	960	960	1,220	1,220	1,500	710	800
440	640	640	840	840	1,070	1,070	1,370	1,370	1,690	800	900
490	710	710	930	930	1,190	1,190	1,520	1,520	1,860	900	1,000
530	770	770	1,030	1,030	1,300	1,300	1,670	1,670	2,050	1,000	1,120
570	830	830	1,120	1,120	1,420	1,420	1,830	1,830	2,250	1,120	1,250
620	910	910	1,230	1,230	1,560	1,560	2,000	2,000	2,470	1,250	1,400



## 8.3 Preload

Normally, bearings are used with a slight internal clearance under operating conditions. However, in some applications, bearings are given an initial load; this means that the bearings' internal clearance is negative before operation. This is called "preload" and is commonly applied to angular ball bearings and tapered roller bearings.

### 8.3.1 Purpose of preload

The following results are obtained by constant elastic compressive force applied to the contact points of rolling elements and raceway by providing preload.

- (1) Bearing's rigidity increases, internal clearance tends not to be produced even when heavy load is applied.
- (2) The particular frequency of the bearing increases and is becomes suitable for high-speed rotation.
- (3) Shaft runout is suppressed; rotation and position precision are enhanced.
- (4) Vibration and noise are controlled.
- (5) Sliding of rolling elements by turning, spinning, or pivoting, is controlled and smearing is reduced.
- (6) Fretting produced by external vibration is prevented.

**Applying excessive preload could result in reduction of life, abnormal heating, or increase in turning torque. You should therefore consider the objectives before determining the amount of preload.**

Table 8.12 Preloading methods and characteristics

Method	Basic pattern	Applicable bearings	Object	Characteristics	Applications
Fixed position preload		Angular contact ball bearings	Maintaining accuracy of rotating shaft, preventing vibration increasing rigidity	Preloading is accomplished by a predetermined offset of the rings or by using spacers. For the standard preload see <b>Table 8.13</b> .	Grinding machines, lathes, milling machines, measuring instruments
		Tapered roller bearings, thrust ball bearings, angular contact ball bearings	Increasing bearing rigidity	Preload is accomplished by adjusting a threaded screw. The amount of preload is set by measuring the starting torque or axial displacement.	Lathes, milling machines, differential gears of automotives, printing machines, wheel axles
Constant pressure preload		Angular contact ball bearings, deep groove ball bearings, tapered roller bearings (high speed)	Maintaining accuracy and preventing vibration and noise with a constant amount of preload without being affected by loads or temperature	Preloading is accomplished by using coil or belleville springs. for deep groove ball bearings: $4 \sim 10 d$ N $0.4 \sim 1.0 d$ {kgf} $d$ : Shaft diameter mm for angular contact ball bearings: see Table 8.13.	Internal grinding machines, electric motors, high speed shafts in small machines, tension reels
		Spherical roller thrust bearings, cylindrical roller thrust bearings, thrust ball bearings	Preload is primarily used to prevent smearing of opposite axial load side when bearing an axial load.	Preload is accomplished by using coil or belleville springs. Recommended preloads are as follows: for thrust ball bearings: $T_1 = 0.42 (nC_{oa})^{1.9} \times 10^{-13}$ N $= 3.275 (nC_{oa})^{1.9} \times 10^{-13}$ {kgf} $T_2 = 0.00083 C_{oa}$ N {kgf} which ever is greater for spherical roller thrust bearings, cylindrical roller thrust bearing $T = 0.025 C_{oa}^{0.8}$ N $= 0.0158 C_{oa}^{0.8}$ {kgf}	Rolling mills, extruding machines

Note: In the above formulas  
 $T$  = preload, N {kgf}  
 $n$  = number of revolutions,  $\text{min}^{-1}$   
 $C_{oa}$  = basic static axial load rating, N {kgf}

### 8.3.2 Preloading methods and amounts

The most common method of applying preload on a bearing is change the relative position of the inner and outer rings of the bearing in the axial direction while applying an axial load between bearings on opposing sides. There are two types of preload: fixed position preload and constant pressure preload.

The basic pattern, purpose and characteristics of bearing preloads are shown in **Table 8.12**. The fixed position preload is effective for positioning the two bearings and also for increasing the rigidity. Due to the use of a spring for the constant pressure preload, the preloading amount can be kept constantly, even when the distance between the two bearings fluctuates under the influence of operating heat and load.

Also, the standard preloading amount for the paired angular contact ball bearings is shown in **Table 8.13**. Light and normal preload is applied to prevent general vibration, and medium and heavy preload is applied especially when rigidity is required.

### 8.3.3 Preload and rigidity

The increased rigidity effect preloading has on bearings is shown in **Fig. 8.2**. When the offset inner rings of the two paired angular contact ball bearings are pressed together, each inner ring is displaced axially by the amount  $\delta_o$  and is thus given a preload,  $F_o$ , in the direction. Under this condition, when external axial load  $F_a$  is applied, bearing I will have an increased displacement by the amount  $\delta_a$  and bearing II's displacement will decrease. At this time the loads applied to bearing I and II are  $F_I$  and  $F_{II}$ , respectively.

Under the condition of no preload, bearing I will be displaced by the amount  $\delta_b$  when axial load  $F_a$  is applied. Since the amount of displacement,  $\delta_a$ , is less than  $\delta_b$ , it indicates a higher rigidity for  $\delta_a$ .

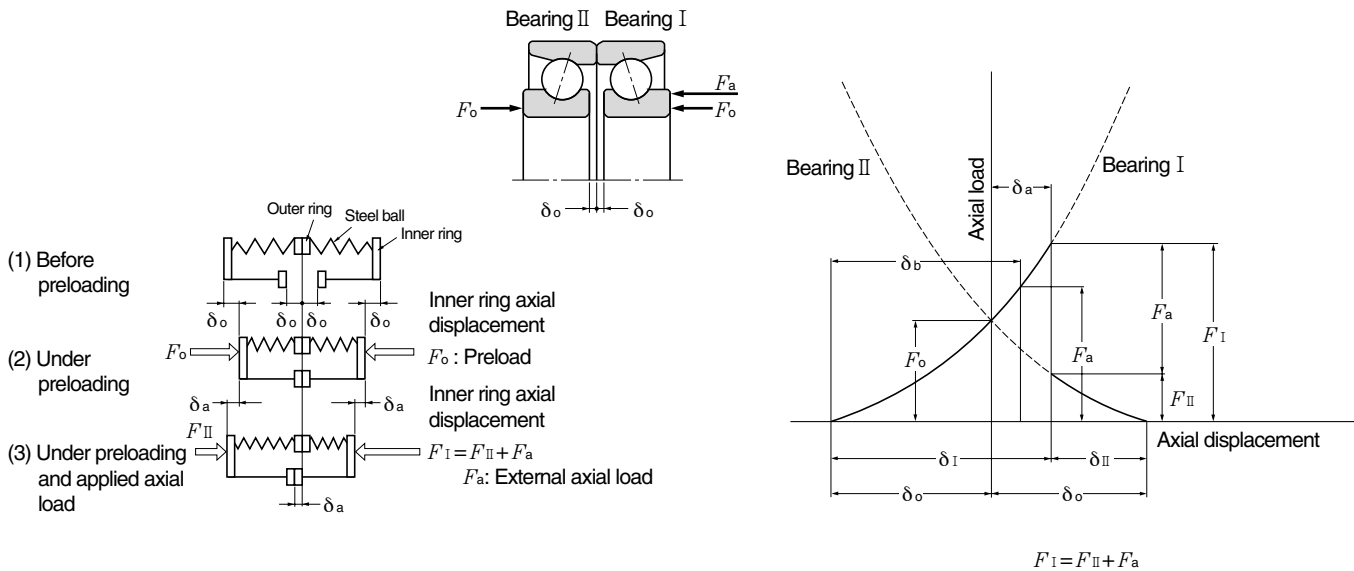

Fig. 8.2 Fixed position preload model diagram and preload diagram

**Table 8.13 The normal preload of duplex angular contact ball bearings**

Nominal bore diameter <i>d</i> mm		Bearing							
		79				70			
over	incl.	Low GL	Normal GN	Central GM	Heavy GH	Low GL	Normal GN	Central GM	Heavy GH
—	12	—	39 { 4}	78 { 8}	147 { 15}	29 { 3}	78 { 8}	147 { 15}	196 { 20}
12	18	—	49 { 5}	147 { 15}	196 { 20}	29 { 3}	78 { 8}	147 { 15}	294 { 30}
18	32	29 { 3}	98 { 10}	196 { 20}	294 { 30}	49 { 5}	147 { 15}	294 { 30}	490 { 50}
32	40	49 { 5}	147 { 15}	294 { 30}	590 { 60}	78 { 8}	294 { 30}	590 { 60}	885 { 90}
40	50	49 { 5}	196 { 20}	390 { 40}	685 { 70}	78 { 8}	294 { 30}	590 { 60}	980 { 100}
50	65	78 { 8}	245 { 25}	490 { 50}	785 { 80}	147 { 15}	490 { 50}	880 { 90}	1,470 { 150}
65	80	98 { 10}	390 { 40}	785 { 80}	1,180 { 120}	147 { 15}	590 { 60}	1,470 { 150}	1,960 { 200}
80	90	147 { 15}	490 { 50}	980 { 100}	1,470 { 150}	196 { 20}	885 { 90}	1,960 { 200}	2,940 { 300}
90	95	147 { 15}	490 { 50}	980 { 100}	1,470 { 150}	196 { 20}	885 { 90}	1,960 { 200}	2,940 { 300}
95	100	196 { 20}	685 { 70}	1,270 { 130}	1,960 { 200}	196 { 20}	885 { 90}	1,960 { 200}	2,940 { 300}
100	105	196 { 20}	685 { 70}	1,270 { 130}	1,960 { 200}	294 { 30}	980 { 100}	2,450 { 250}	3,900 { 400}
105	110	196 { 20}	685 { 70}	1,270 { 130}	1,960 { 200}	294 { 30}	980 { 100}	2,450 { 250}	3,900 { 400}
110	120	245 { 25}	885 { 90}	1,780 { 180}	2,940 { 300}	294 { 30}	980 { 100}	2,450 { 250}	3,900 { 400}
120	140	294 { 30}	980 { 100}	1,960 { 200}	3,450 { 350}	490 { 50}	1,470 { 150}	3,450 { 350}	5,900 { 600}
140	150	390 { 40}	1,270 { 130}	2,450 { 250}	4,400 { 450}	490 { 50}	1,470 { 150}	3,450 { 350}	5,900 { 600}
150	160	390 { 40}	1,270 { 130}	2,450 { 250}	4,400 { 450}	685 { 70}	2,450 { 250}	4,900 { 500}	8,850 { 900}
160	170	390 { 40}	1,270 { 130}	2,450 { 250}	4,400 { 450}	685 { 70}	2,450 { 250}	4,900 { 500}	8,850 { 900}
170	180	490 { 50}	1,770 { 180}	3,450 { 350}	5,900 { 600}	685 { 70}	2,450 { 250}	4,900 { 500}	8,850 { 900}
180	190	490 { 50}	1,770 { 180}	3,450 { 350}	5,900 { 600}	885 { 90}	3,450 { 350}	6,850 { 700}	9,800 { 1,000}
190	200	685 { 70}	2,450 { 250}	4,900 { 500}	7,850 { 800}	885 { 90}	3,450 { 350}	6,850 { 700}	9,800 { 1,000}

unit N {kgf}

series							
72, 72B				73, 73B			
Low GL	Normal GN	Central GM	Heavy GH	Low GL	Normal GN	Central GM	Heavy GH
29 { 3}	98 { 10}	196 { 20}	294 { 30}	49 { 5}	147 { 15}	294 { 30}	390 { 40}
29 { 3}	98 { 10}	294 { 30}	390 { 40}	49 { 5}	147 { 15}	390 { 40}	490 { 50}
78 { 8}	196 { 20}	490 { 50}	785 { 80}	98 { 10}	294 { 30}	590 { 60}	980 { 100}
98 { 10}	390 { 40}	885 { 90}	1,470 { 150}	147 { 15}	490 { 50}	980 { 100}	1,960 { 200}
147 { 15}	590 { 60}	980 {100}	1,960 { 200}	196 { 20}	785 { 80}	1,470 { 150}	2,450 { 250}
196 { 20}	785 { 80}	1,470 {150}	2,940 { 300}	294 { 30}	980 {100}	2,450 { 250}	3,900 { 400}
294 { 30}	980 {100}	2,450 {250}	3,900 { 400}	390 { 40}	1,470 {150}	3,450 { 350}	4,900 { 500}
490 { 50}	1,470 {150}	2,940 {300}	4,900 { 500}	590 { 60}	1,960 {200}	3,900 { 400}	5,900 { 600}
490 { 50}	1,960 {200}	3,900 {400}	5,900 { 600}	590 { 60}	2,450 {250}	4,900 { 500}	6,850 { 700}
490 { 50}	1,960 {200}	3,900 {400}	5,900 { 600}	590 { 60}	2,450 {250}	4,900 { 500}	6,850 { 700}
590 { 60}	2,450 {250}	4,900 {500}	7,850 { 800}	685 { 70}	2,940 {300}	5,900 { 600}	8,850 { 900}
590 { 60}	2,450 {250}	4,900 {500}	7,850 { 800}	685 { 70}	2,940 {300}	5,900 { 600}	8,850 { 900}
590 { 60}	2,450 {250}	4,900 {500}	7,850 { 800}	685 { 70}	2,940 {300}	5,900 { 600}	8,850 { 900}
785 { 80}	2,940 {300}	5,900 {600}	9,800 {1,000}	885 { 90}	3,900 {400}	7,850 { 800}	11,800 {1,200}
785 { 80}	2,940 {300}	5,900 {600}	9,800 {1,000}	885 { 90}	3,900 {400}	7,850 { 800}	11,800 {1,200}
885 { 90}	3,900 {400}	7,850 {800}	11,800 {1,200}	980 {100}	4,400 {450}	8,800 { 900}	13,700 {1,400}
885 { 90}	3,900 {400}	7,850 {800}	11,800 {1,200}	980 {100}	4,400 {450}	8,800 { 900}	13,700 {1,400}
885 { 90}	3,900 {400}	7,850 {800}	11,800 {1,200}	980 {100}	4,400 {450}	8,800 { 900}	13,700 {1,400}
980 {100}	4,400 {450}	8,850 {900}	13,700 {1,400}	1,470 {150}	5,900 {600}	11,800 {1,200}	15,700 {1,600}
980 {100}	4,400 {450}	8,850 {900}	13,700 {1,400}	1,470 {150}	5,900 {600}	11,800 {1,200}	15,700 {1,600}